

K-Net Auto

Automatic filling machine

Automatic filler - Type of filling: Piston, flowmeter or peristaltic pump. Minimum dose: 50 ml and maximum dose: 20 L (depending on configuration and options chosen).



The K-Net Auto is an automatic filling machine equipped with :

- All-stainless steel frame.
- Motorized conveyor.
- Designed to accommodate one or two dosing stations.
- Dosing valve and spout.
- A centering device for correct positioning of the bottle under the filling spout.
- Liquid recovery chutes under the conveyor.
- Tamping cell at machine exit.
- Touch screen for setting and controlling the machine.

Available options

- A system to feed the containers (cylindrical table, rectangular table, transfer plate).
- A mass or electromagnetic flow meter.
- A centrifugal, volumetric pump with flexible impeller or eccentric screw.
- A piston (different dosing devices possible).
- An additional dosing nozzle (short, standard, swivel...).
- A stainless steel hopper to feed the pump with product.
- A remote loading device.
- One VS400 capping machine.
- One VS500 capping machine.
- A cap pushing station.
- A crimping station.
- A heat-sealing machine.
- A system to receive the containers (cylindrical table, rectangular table, transfer plate).

Limits of the K-Net Auto

- Dosing volumes of less than 50ml (1.7oz) and more than 5L.

Before placing an order, we can carry out tests free of charge to ensure the feasibility of your project. Please do not hesitate to contact us!

Technical characteristics K-Net Auto

APPROXIMATE MASS (KG)	450 kg (depending option)
DIMENSIONS (WITH FRAME)	1010 mm in width 1800 mm in height 3670 mm of depth
POWER CONSUMPTION	1 kW
SUPPLY VOLTAGE	208-250 V single phase
FREQUENCY	~ 50 Hz 16 A
CONTROL	by touch screen
IDEAL OPERATING TEMPERATURE	from 10°C to 30°C

Please note that this machine requires an electrical and pneumatic power supply.

Technical Focus n°1

PNEUMATIC / POWER SUPPLY

Pneumatic connection: 1 air connection on pressure gauge - Under 6 bars constant (Hose to be provided \varnothing Int/Ext = 8/10 mm).

Electrical connection: 1 Cable 220 volts - length 6 metres - Domestic socket.

Technical Focus n°2

DIGITAL DISPLAY

The color touch screen allows easy adjustment of several parameters such as:

Dose adjustment.

A production counter.

Technical Focus n°3

FLOW METERING

Flowmeter metering is generally used for free-flowing to slightly thick products without lumps in suspension. It is carried out by the action of a rotary pump, a flow meter and a dosing head. The mass flowmeter is compatible with all types of product and allows dosing by mass, while the electromagnetic flowmeter is only compatible with conductive products and allows dosing by volume.

Technical Focus n°4

PISTON DOSING

Piston dosing is generally used for packaging liquid to dense products or with pieces in suspension.

By means of a suction system, the product is introduced into the dosing chamber of the piston. When the predefined quantity is reached, the piston pushes the product towards the valve and then towards the dosing head.

Technical Focus n°5

VS400

VS400 capping station including:

- A product detection and stopping device for manual application of caps with a cap presence control cell.
- A product detection and stopping device under the screwing head, with a pneumatic cylinder with «V» tip and anti-rotation plate.
- Screwing machine with electric height adjustment.
- Screwing head designed for one cap format.

Technical Focus n°6

VS500

VS500 capping station including:

- A jar holding and stopping device for manual capping with a capping presence control cell.
- A device for holding and stopping the products under the screwing head, with a pneumatic cylinder with a «V» tip and anti-rotation plate.
- Screwing of the pump/caps with two belts (lateral displacement of the belts).
- Tightening torque and screwing height adjustment.

Technical Focus n°7

PUSHER

Pneumatic pushing station including:

- A bottle detection and stopping device for manual cap placement
- Cap presence control cell
- A device for holding and stopping the jars by symmetrical centering of the bottles under the capping head.
- A height-adjustable pneumatic cylinder to push the cap onto the neck of the bottle

Technical Focus n°8

CRIMPING

Crimping station including:

- Pneumatically guided bottle clamping system with product-specific cylinder head
- Crimping system on electrically height adjustable double guide
- Crimping unit mounted on pneumatic cylinder
- Crimping head adapted to the geometry of your cap (diameter, height, etc.)
- Crimping station can be dismantled

Technical Focus n°9

INDUCTION SEALER

Induction sealing station comprising:

- A 3.6 kW induction heat sealing generator
- A universal inductor (for sealing flat caps)
- A height adjustable mobile jib

Technical Focus n°10

ACCUMULATION TABLE

The accumulation table is installed at the machine exit to collect the labeled bottles. The 700 mm diameter table can receive up to 60 bottles. The accumulation table allows the operator to save considerable time.

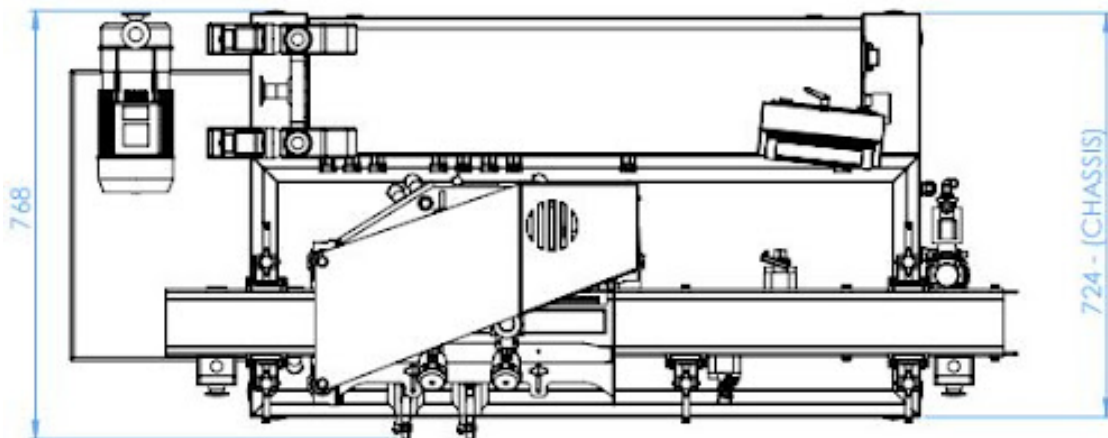
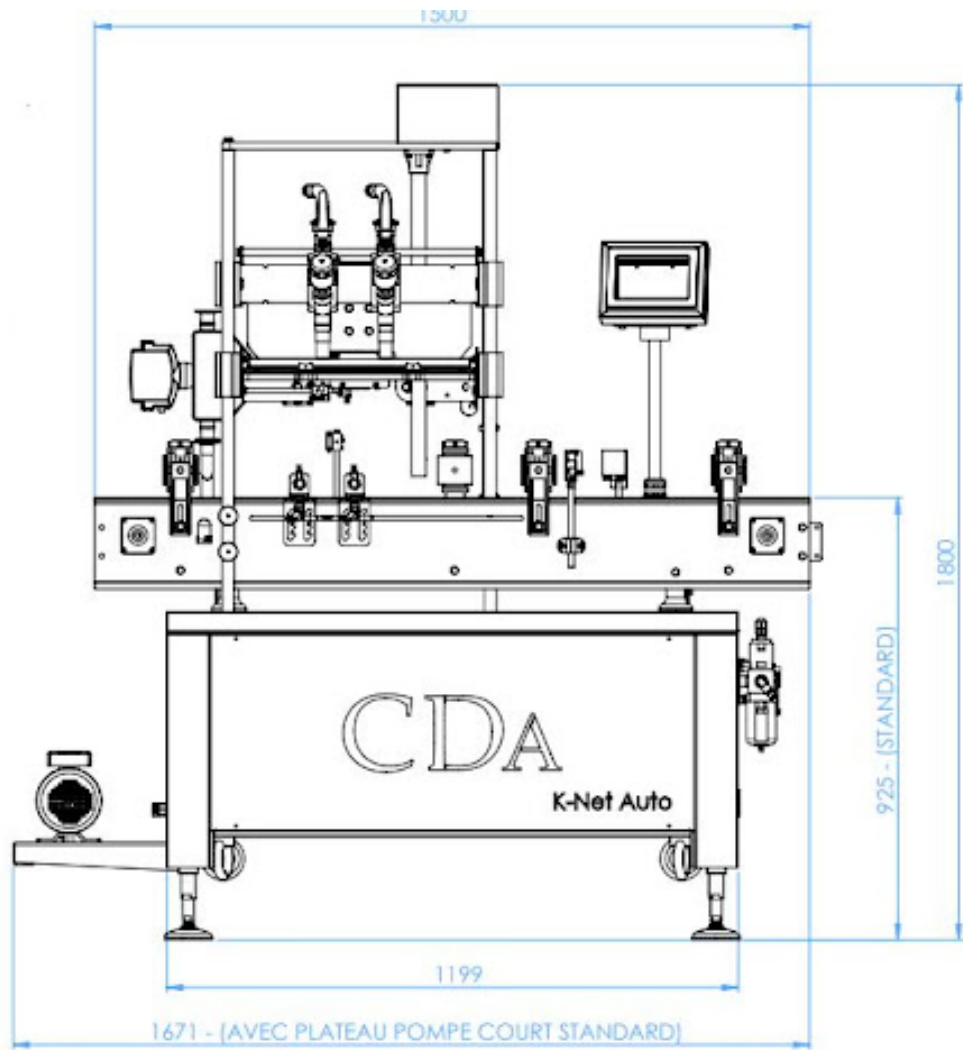

Pictures, production rates and technical descriptions for information.