



CHABOT DELRIEU ASSOCIÉS

Lystop 2

Automatic Labelling Machine

Wine Industry

Lystop 2

Automatic Labelling Machine

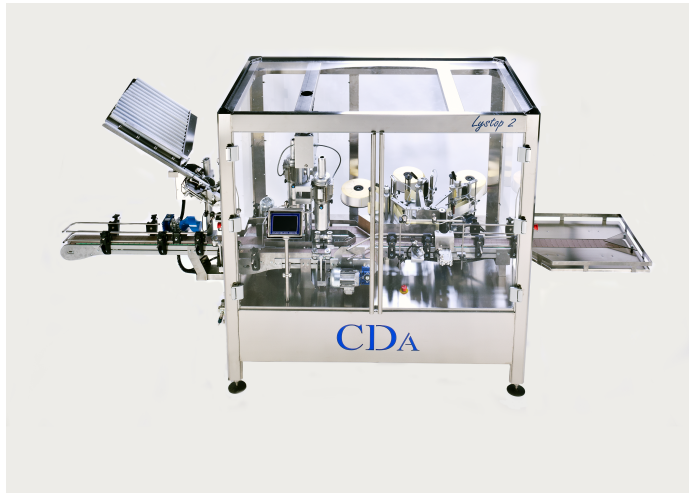

General description

The Lystop enables up to 4 labels applications and the crimping of metallic or PVC capsules. Production rate up to 2500 bottles/hour.

Equipped machine

Motorized conveyor

- ▶ Anodized aluminium profile, created by CDA, receiving an acetal slate band conveyor, width 82,5 mm ;
- ▶ The stainless steel side guide bars in Ø12 mm are adjustable in width to allow the passage of a bottle up to Ø 110 mm in and 390 mm height ;
- ▶ The motorized conveyor is built on a stainless steel frame, outfitted with blue side panels in which the electrics & electronics are integrated. Four feet on wheels allow its displacement ;
- ▶ A multi-format selection screw with a frequency converter is at the entrance of the machine to regulate the space between the bottles and the feeding speed ;
- ▶ A rotating reception table Ø 700 mm is built at the outlet of the conveyor to collect the labelled bottles.

Capsule Dispenser

- ▶ A feeding plate for capsules of 500 by 430 mm ;
- ▶ Capsule diameter of 30 mm ± 2mm, bigger in option on request ;
- ▶ Capsule length from 30 to 55 mm ;
- ▶ Ejection of the capsules by two blowers with length and width adjustable according to the size of capsules ;
- ▶ Automatic centring and hold of the bottle necks during capsule dispensing ;
- ▶ Detection cell to detect the presence of the corks in order to avoid dispensing a capsule on an unclosed bottle ;
- ▶ Automatic centring and hold of the bottle from 60 to 110 mm de Ø without any necessity of adjustment for bottle size change ;
- ▶ Regulation of the speed and validation through the digital display.

Capsuling

- ▶ A capsule crimper turning at 2 800 rpm, and which slides down (110 mm slide) to roll the capsule onto the bottle's neck ;
- ▶ And/or thermal crimper with heat regulation (110 mm slide) ;
- ▶ The height adjustment is motorised and regulated through the digital display ;
- ▶ The bottle holders are ensuring an automatic centring and hold of all diameters from Ø 60 to 110 mm without necessity of adjustment for bottle size change ;
- ▶ Bottle neck diameter: 30 mm ± 2 mm ;
- ▶ Regulation of the sliding speed (up & down) through independent air limiters ;
- ▶ Speed regulation and validation of the capsuling process through the digital display.

Labelling

- ▶ One label dispenser for front labels ;
- ▶ One label dispenser for back labels ;
- ▶ One label dispenser for a third label to be applied on the cylindrical part of the bottle or one label dispenser for medals or collar labels ;
- ▶ All label dispensers steered by asynchronous motors piloted by vectorial frequency converters;
- ▶ The height regulation of each label dispensers is motorized ;
- ▶ Labelling height adjustment through digital display ;
- ▶ From 8 to 300 mm label height ;
- ▶ Nominal labelling production rate for front/back labels: 2 500 bt/h ;
- ▶ Adjustment and memorizing of the label positioning through the digital display .

Digital Display

- ▶ Validation zones ;
- ▶ Zone for regulation settings ;
- ▶ Zone for bottle counter ;
- ▶ Adjustment of the label positioning ;
- ▶ Setting of production rate and process timing ;
- ▶ Positioning memorizing - 50 positions ;
- ▶ Labelling height adjustment ;
- ▶ Process error detection and self-diagnosis.



Options

- ▶ Lot marker by heat transfer ;
- ▶ Detection cell for the positioning of an additional label on already labelled bottles ;
- ▶ Detection cell for the positioning of labels on notched bottles;
- ▶ Additional conveyor length ;
- ▶ Guiding unit for cone shaped bottles ;
- ▶ Ink jet lot marker ;
- ▶ Ultrasonic label detection sensor for transparent labels .

Technical Description

Performance	Jusqu'à 2500 bouteilles/heure
Approximate weight in kgs	250 kg
Machine width	1400 mm
Machine height	2100 mm
Machine length	3800 mm
Conveyor entrance	1200 mm
Control	By digital display
Power supply	380 V ~ 50 Hz 16A 3 Phases + Ground 16A 220 V ~ 50 Hz 16A
Absorbed power	2kw
Air consumption	20 m ³ / hour maxi at 6 bars – Dry air non lubricated
Ideal running temperature	From 10°C to 30°C

Dimensions of the label rolls

A - Inside diameter: 75 mm

B - Outside max diameter: 260 mm

C - Max. band height: 160 mm (or more on demand)

D - Space between labels: 3-5 mm

► Winding Direction : Left Out

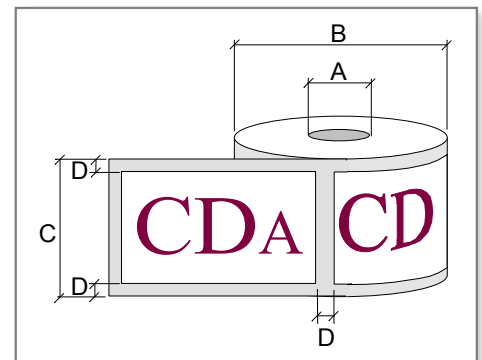

Minimal paper quality : 90g.

Nota: The rolls have to be stored in a dry place between 15°C and 18°C.

Machine delivered with EC Standards.

Non contractual documents.

Schéma Lystop 2

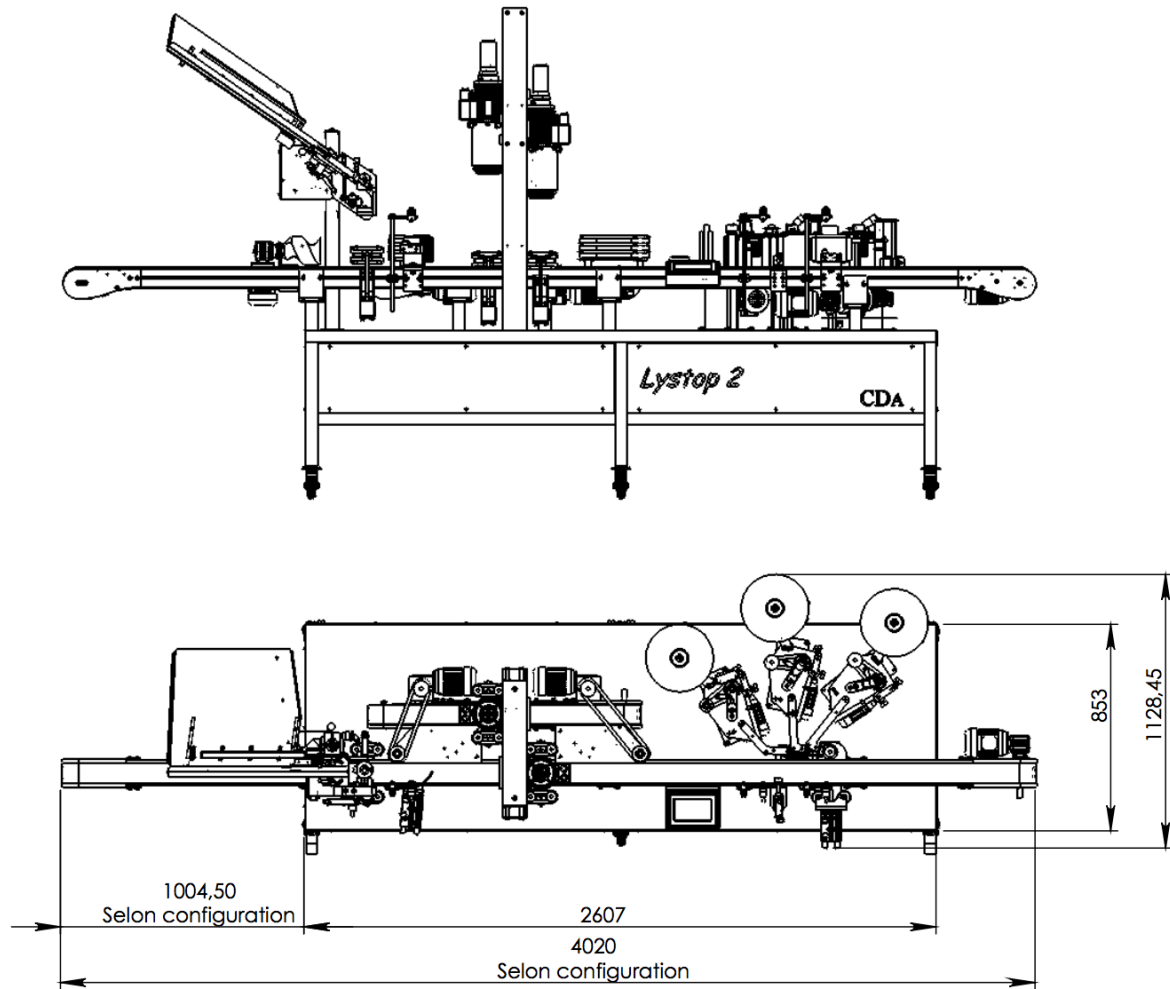



CHABOT DELRIEU ASSOCIÉS