

# DistriCap

## Automatic lid dispensing & placing machine

Automatic lid dispensing & placing machine

The DistriCap is an automatic dispensing module for twist-off capsules which automatically dispense and place "on the fly" the lids on the containers.



## The DistriCap is an Automatic lid dispensing equipped with :

- A stainless steel storage hopper (lower part of the lift)
- A vertical conveyor allowing the orientation of the capsules
- An "On-the-fly" dispensing head
- A caps detection sensor in the ramp
- Motorised lateral transfer belt under the deposit head
-

## Available options

- Additional screwing head
- For caps lifter/dispenser: Drop ramp & dispensing head for another type of twist off caps

*Before placing an order, we can carry out tests free of charge to ensure the feasibility of your project. Do not hesitate to contact us!*

## Technical characteristics DistriCap

APPROXIMATE MASS (LBS)	100 kg (depending on option)
POWER CONSUMPTION	1 kW
SUPPLY VOLTAGE	220 V mono
FREQUENCY	~ 50 Hz 16 A
CONTROL	On the filling machine touch screen
IDEAL OPERATING TEMPERATURE	from 10°C to 30°C

**Please note that this machine requires an electrical and pneumatic power supply**

### Technical focus n°1

#### ELECTRICAL CONNECTION

Electrical connection: 1 Cable 220 volts - length 6 meters - Domestic socket.

### Technical focus n°2

#### SCREWING HEAD

The screwing heads are made to measure according to the samples (caps) specified at the time of the order and received by our quality department. A change or addition of a cap would require a change of tooling.

### Technical focus n°3

#### DESCENT RAMP ET REMOVAL HEAD

The Twist Off cap dispensing manifolds are custom designed according to the samples (caps) specified at the time of order and received by our quality department. Changing or adding a cap would require a change of tooling.

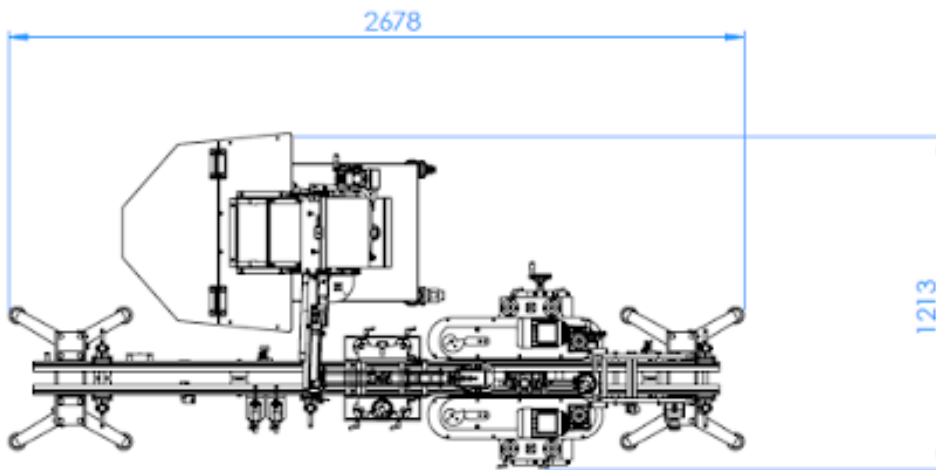
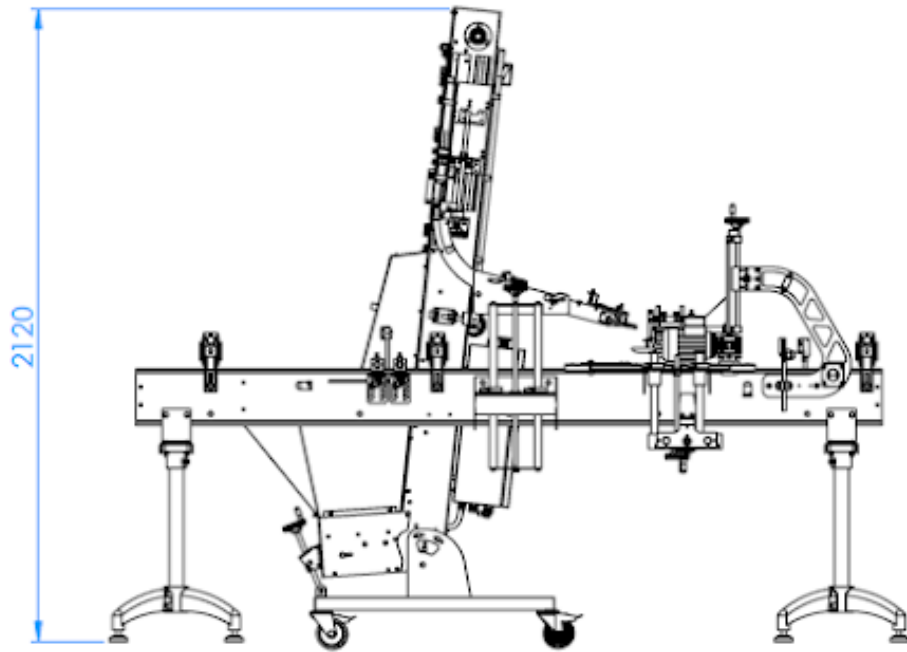

*Photos, rates and descriptions are indicative and not contractual*